

## SPK SOLAR PANEL KIT INSTALLATION INSTRUCTIONS

### 1. PV ARRAY PANEL INSTALLATION

#### 1.1 INSTALLING THE PANEL

The following exploded illustration **Figure 2** shows the included hardware required to properly mount the array panel to a vertical pole. (20 Watt PV array panel shown).

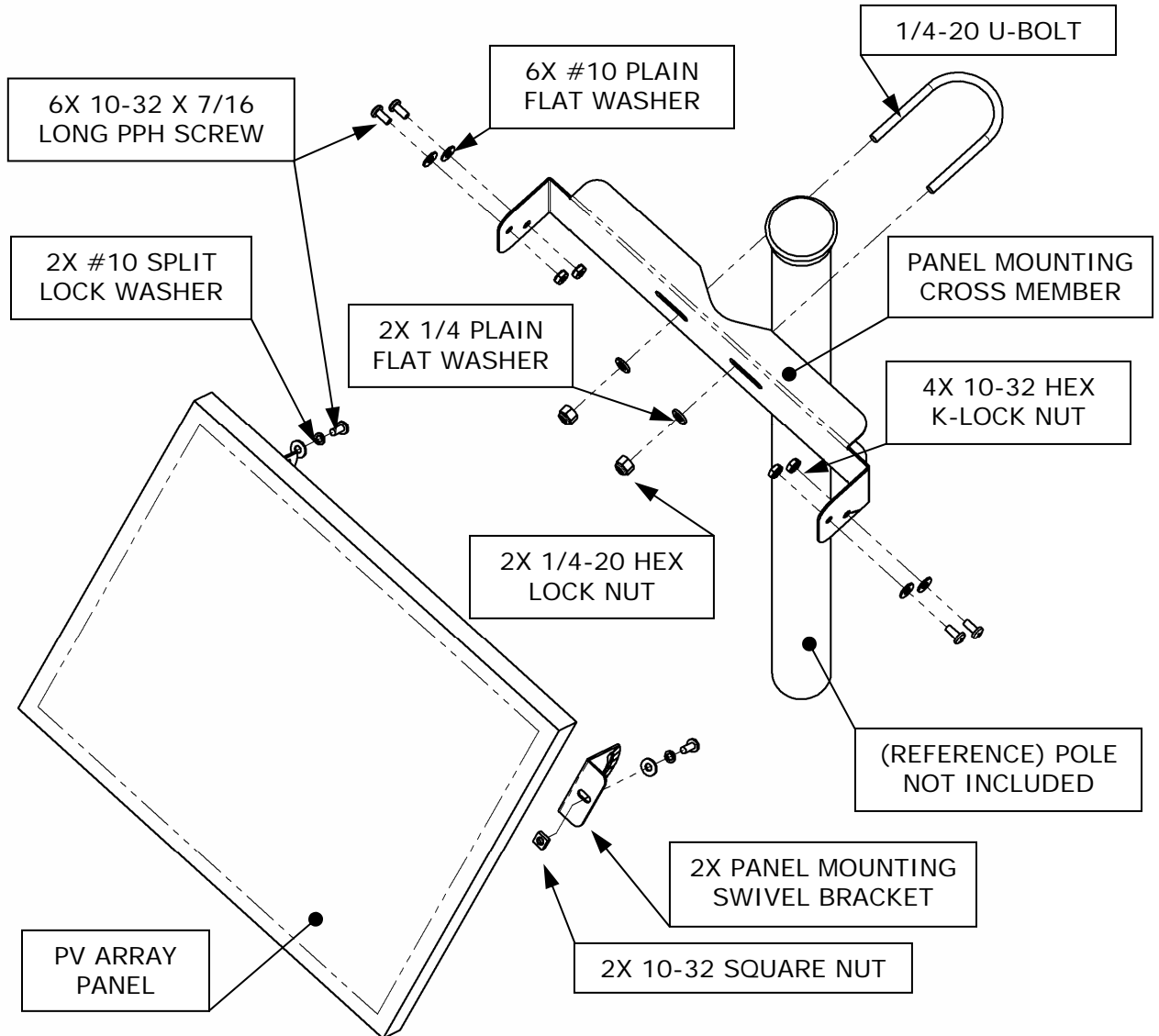

**Figure 2**

The swivel brackets are to be mounted to the sides of the array panel as shown in **Figure 3**.

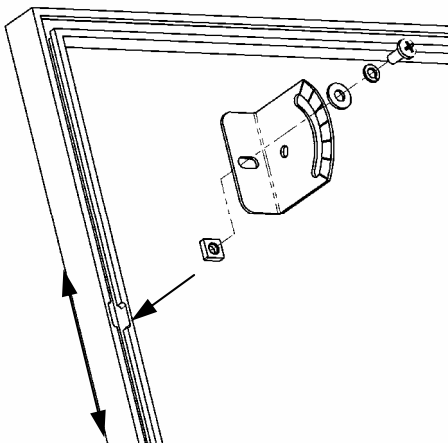

1. Insert the square nuts into the cutouts at each side of the panel and slide in slot to initial position.
2. Assemble swivel brackets with the included hardware to the nuts.
3. Tighten screws securely when brackets are adjusted to the desired position.

**Figure 3**

## 1.2 ADJUSTING THE PANEL

Figure 4 shows the PV array panel mounted to a vertical pole.

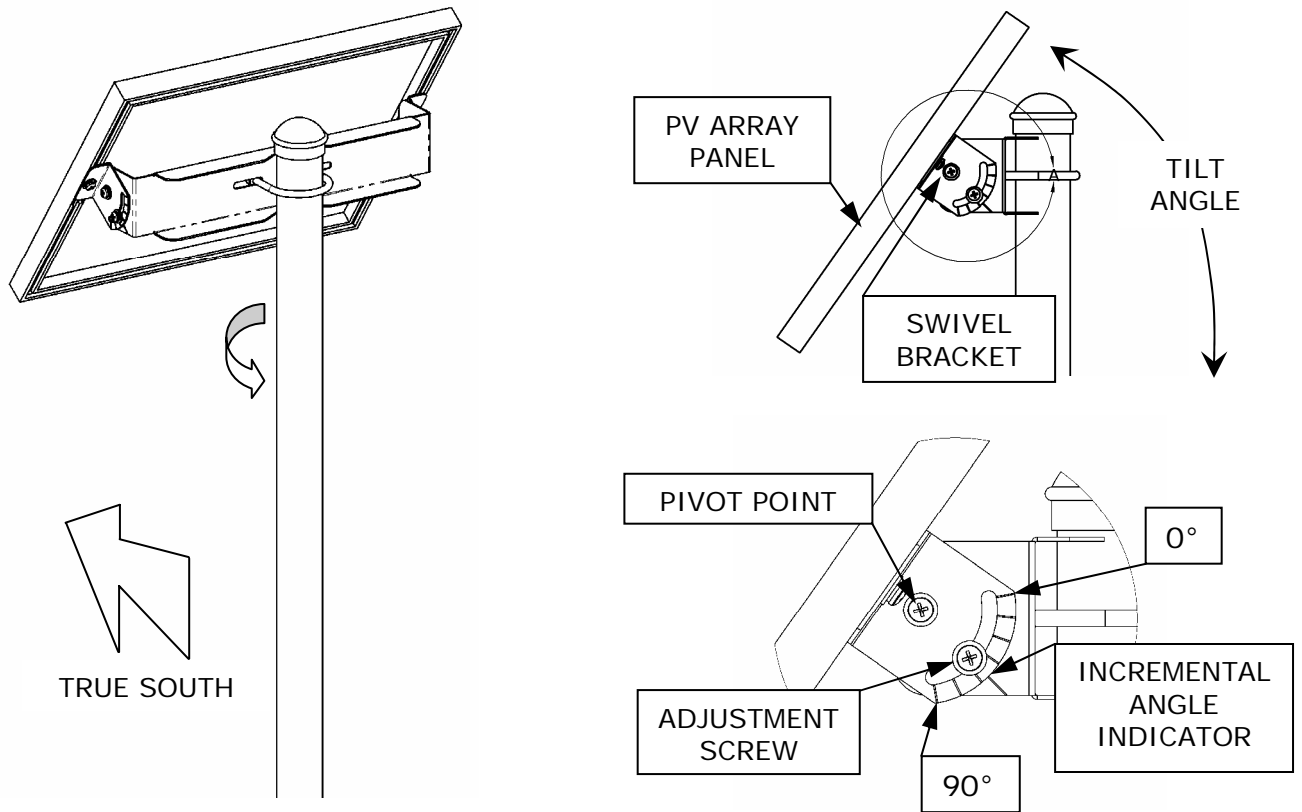

Figure 4

### 1.2.1 DIRECTION

The panel can be adjusted axially to the pole by loosening the U-bolt and rotating the cross member to face the desired true South direction.

It is important for proper solar power system operation that the array panel be oriented toward true South (if you are located in the northern hemisphere). The directions of magnetic South and true South differ from one another depending on geographic location. This variance is called declination.

Check the declination for your region in order to extrapolate true South from a compass heading of magnetic South. There is a map available online which shows the magnetic declination for various locations in the US at: <http://www.securitron.com/en/site/securitron/Library/Solar-Product-Information>. (For example, true south in central Texas falls between the 7 degree East and the 8 degree East lines. This means that, for optimum exposure, the solar panel should be aligned 7-8 degrees east of magnetic South (on a compass).

### 1.2.2 TILT ANGLE

The panel can be adjusted to the desired tilt angle using the swivel bracket at each side of the panel. Simply loosen the pivot and the adjustment screw at each bracket. The brackets are marked at 15° increments from 0° (horizontal) to 90° (vertical). Align the indicator on the bracket to the desired angle, and then tighten the screws.

Optimum tilt angle is measured from horizontal and can be measured using the indication marks on the panel swivel brackets. As a general rule the tilt angle of the panel should be set as follows:

- For **year-round applications** the tilt angle should be set equal to the location latitude (e.g. latitude 40° North = tilt angle 40°).
- For **winter applications** the tilt angle should be set to the location latitude **plus 15°** (e.g. latitude 40° North + 15° = tilt angle 55°).
- For **summer applications** the tilt angle should be set to the location latitude **minus 15°** (e.g. latitude 40° North - 15° = tilt angle 35°).

Note: Seasonally adjusting the tilt angle of the PV array panel can significantly increase power production for year-round loads.

**SECURICARE 3YR WARRANTY** – See website [www.securitron.com](http://www.securitron.com) for complete details.