

MAGNETIC LEAKAGE

We address the issue of magnetic field leakage in this bulletin because of application concerns that can be raised. The first is the possibility of erasing or altering magnetic storage media for computers, such as disks and tapes. The second is the possibility of damaging a heart pacemaker implant, which could be life threatening and the third is possible interference with the magnetic door switches that are often mounted near to Magnalocks.

To evaluate the situation, we made four measurement test series. These covered the Model 32 and Model 62 series Magnalocks with and without the strike plate, coupled. The magnetic field increases significantly when the strike plate is coupled to the magnet body, but leakage is reduced as the field is redirected and confined by the magnet/strike bond.

The first conclusion from the test series, is that at a six inch distance from either Model Magnalock, with or without the strike coupled, field leakage has declined to a point where it's indistinguishable from the earth's background magnetic field of 0.3 Gauss. Therefore, use of the Magnalock, apparently presents a zero risk of altering or erasing magnetic media unless the media is stored for a period of time in close proximity to the Magnalock (under six inches). Considering the position of the Magnalock at the top of a door frame, there is no ordinary risk of any problem arising.

We obtained a safety standard from one pacemaker manufacturer, which said that sources of magnetic fields must provide leakage of under 60 Gauss at six inches to be considered safe for use in areas where pacemaker wearing persons are present. It is probable that this safety standard is representative of all pacemakers, as if a particular model was much more sensitive, the wearer would be at threat from the enormous number of magnetic field sources (motors, transformers, etc.) that are found everywhere. At a six inch distance, Magnalocks emit zero leakage, and to receive a field of 60 Gauss, a pacemaker would have to be brought nearly in contact with the surface of the electromagnet, which is impossible since the pacemaker is an implant.

In assessing possible interference with door switches, we consulted with a leading door switch manufacturer and learned that some sensitive models can have their operation interfered with if a magnetic field as low as 1.5 Gauss is present. This applies equally to the switch element and permanent magnet as the switch element experiences the risk of switching incorrectly and the permanent magnet suffers the risk of being demagnetized by an external field. Measurements taken at the ends of our Magnalocks where a door switch would mount, show that a minimum two inch separation is necessary to guarantee field leakage of less than 1.0

Gauss. To insure proper operation of the door switch, therefore, this minimum separation should be observed. If special physical constraints prevent obtaining this separation, it is likely that interference would still not occur, even if the door switch was butted against the end of the magnet body. This is because different models of switches vary in sensitivity and the direction of field is an important factor. For best reliability however, our recommendation is to strive for a minimum two inch separation for any magnetic contact. The actual field measurements obtained in our test series are attached to this document for reference.

TEST SERIES ONE
MAGNETIC LEAKAGE IN GAUSS- MODEL 62 MAGNALOCK WITH ARMATURE

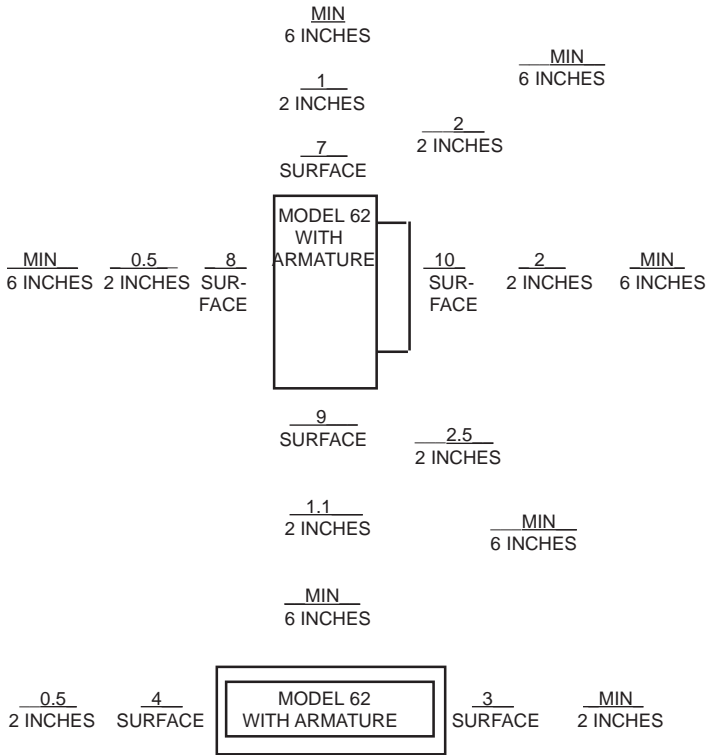

TEST SERIES TWO
MAGNETIC LEAKAGE IN GAUSS- MODEL 62 MAGNALOCK WITHOUT ARMATURE

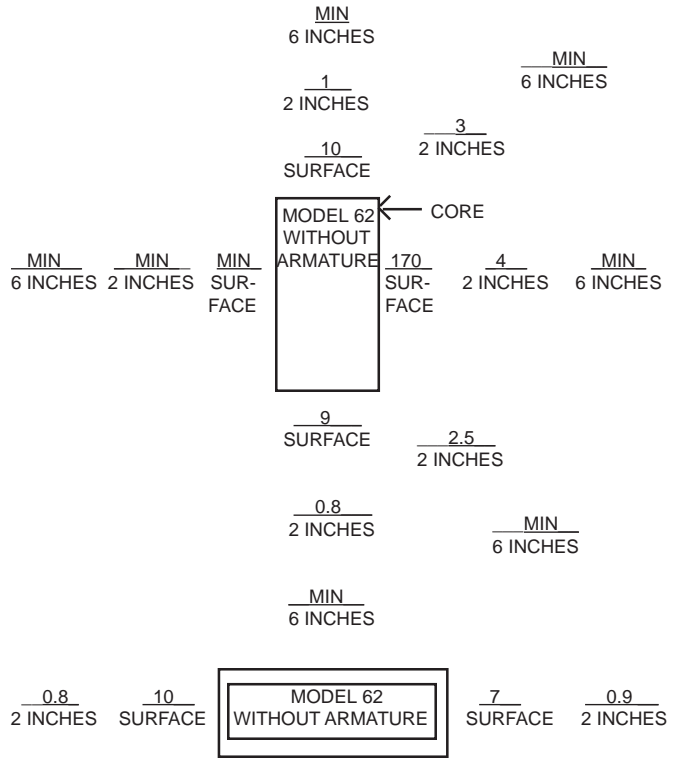

TEST SERIES THREE
MAGNETIC LEAKAGE IN GAUSS- MODEL 32 MAGNALOCK WITH ARMATURE

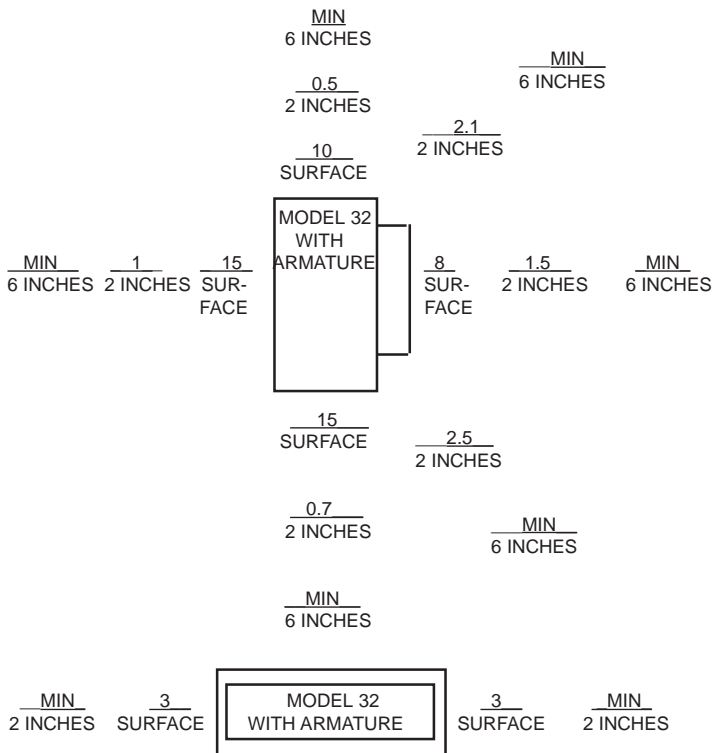

TEST SERIES FOUR
MAGNETIC LEAKAGE IN GAUSS- MODEL 32 MAGNALOCK WITHOUT ARMATURE

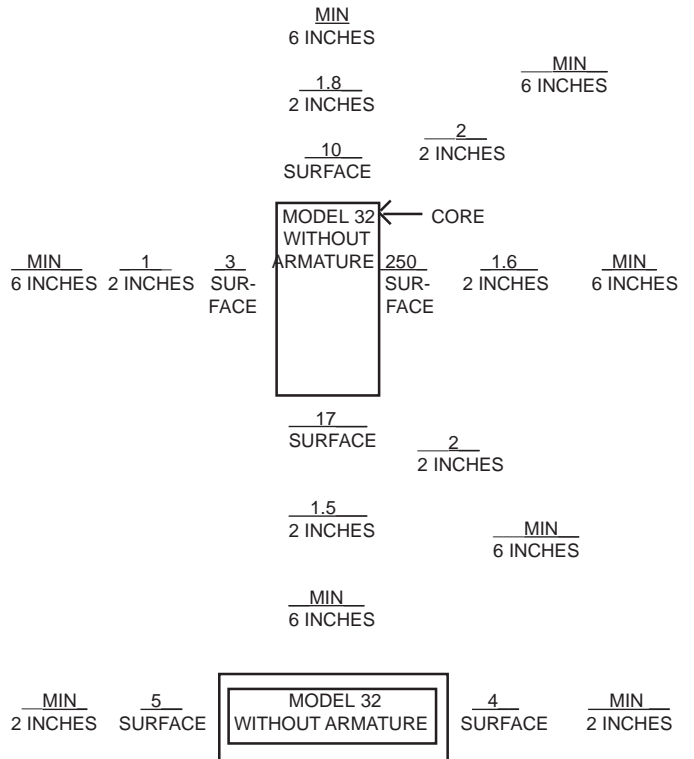

"MIN" MEANS THAT THE LEAKAGE IN GAUSS IS SO LOW AS TO BE INDISTINGUISHABLE FROM THE EARTH'S BACKGROUND MAGNETIC FIELD OF 0.3 GAUSS.